

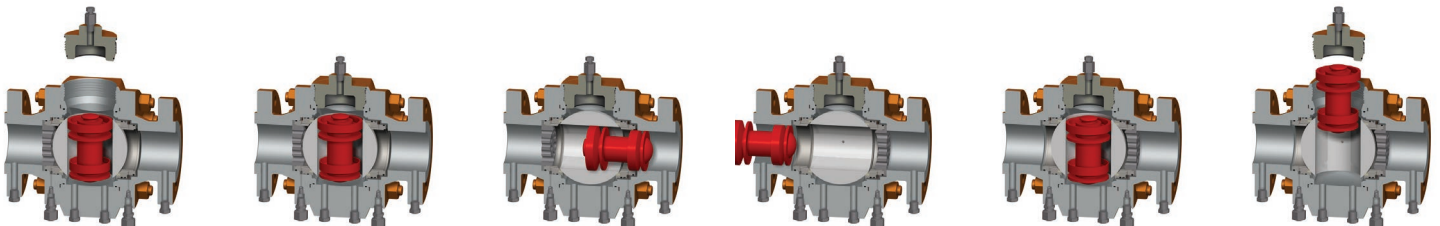

TULSA PIG VALVES  
A CACTUS FLOW PRODUCTS COMPANY

# SHUT-OFF PIG VALVE

COST-EFFECTIVE PIPELINE MAINTENANCE

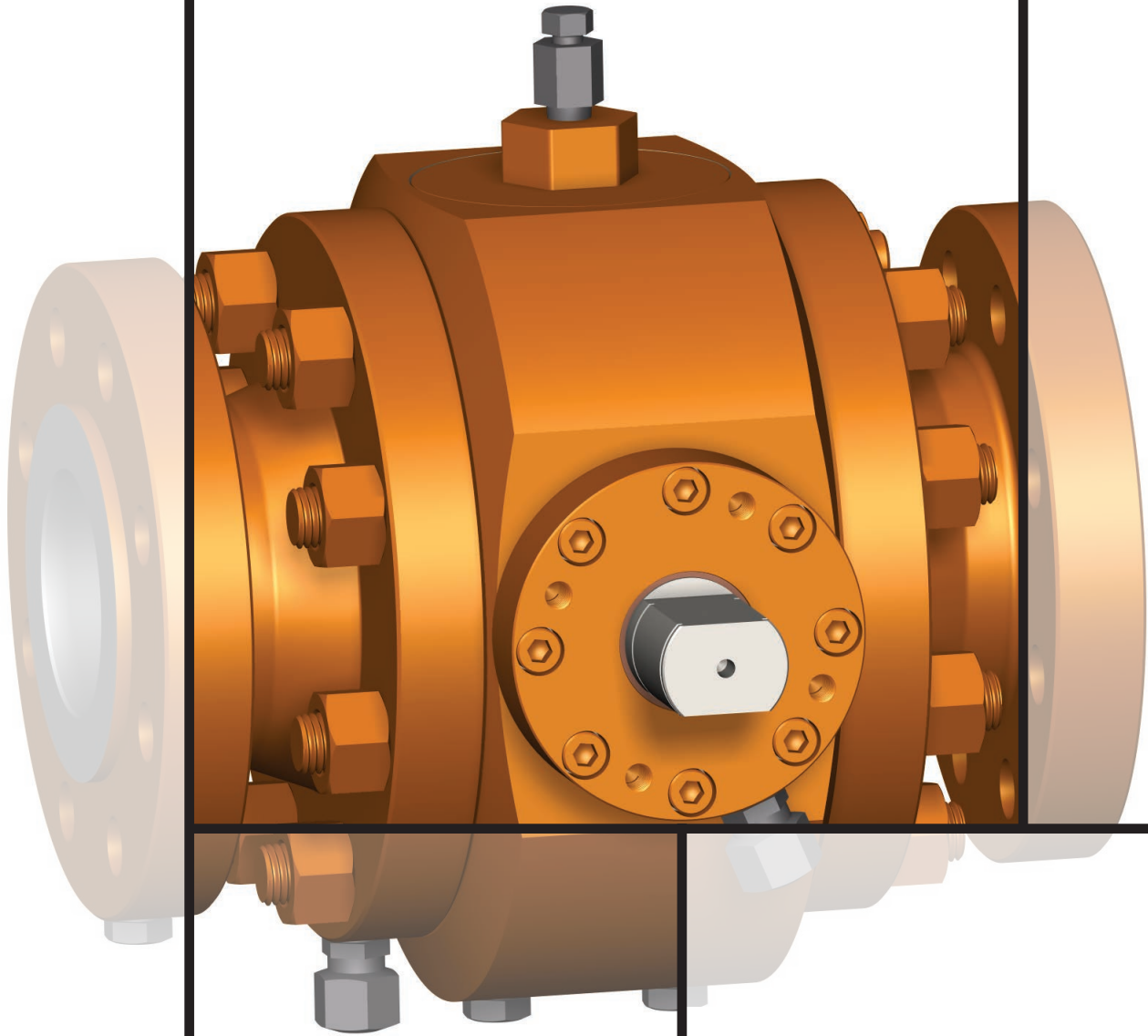

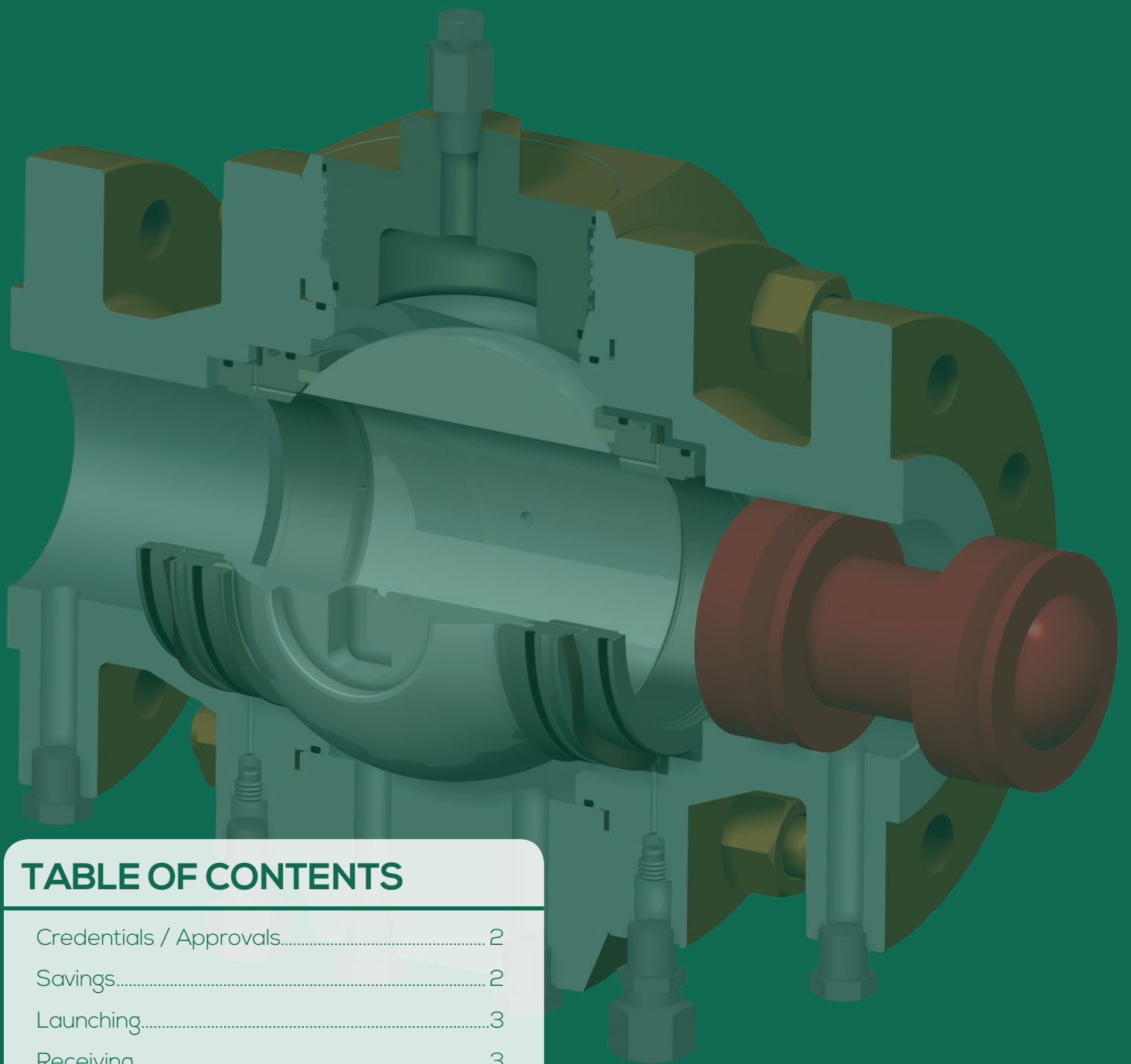

## TABLE OF CONTENTS

Credentials / Approvals.....	2
Savings.....	2
Launching.....	3
Receiving.....	3
Features with Benefits.....	4
Construction & Materials.....	6
Dimensions & Weights.....	8
Pressure / Temperature.....	10
More from Tulsa Valve.....	11
Discover Cactus Flow Products.....	12

# ABOUT TULSA PIG VALVES

Beginning with the first pig valve designed and manufactured in 1996, Tulsa Pig Valve LLC has demonstrated an unwavering drive to remain the preferred vendor for pipeline companies. This vision has always set Tulsa Pig Valves apart from other brands of pig valves.

Through dedication to quality, product innovation, and our commitment to customer service we strive to be the best in class. Our values are grounded in the belief that honesty, integrity, honor and a complete commitment to excellence is how we identify ourselves. We believe that these same characteristics, found in our personnel and our channel partners is the key to our continued growth and success.

We are dedicated to growing and maintaining long-term partnerships with our customers that will provide unsurpassed value and service.

Wellhead thru Midstream / Design thru Aftermarket

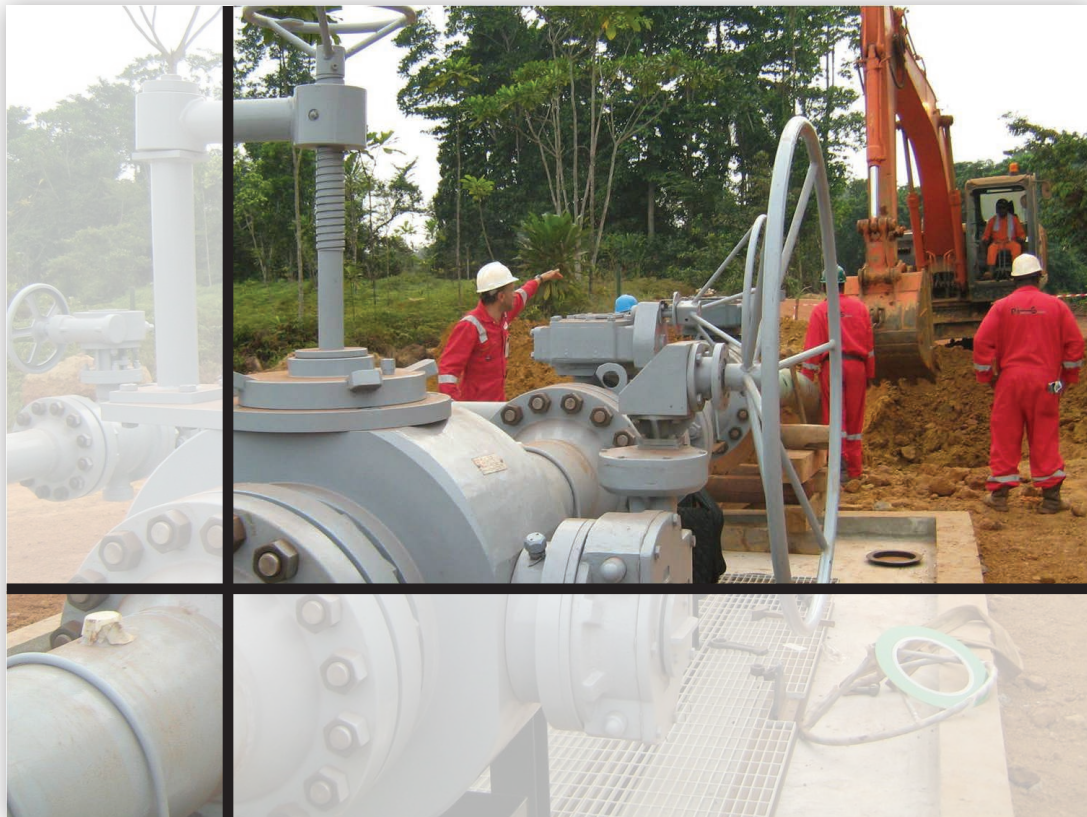

# CREDENTIALS & APPROVALS

Shut-off Pig Valves are trunnion mounted ball valves, designed in accordance with:

- ASME B16.34
- API 6D
- NACE

100% Pressure Testing in accordance with API 6D, API 598

## SAVINGS

Estimated savings range from 25-60% over the traditional barrel and trap systems.

- Smaller Footprint
- Less Equipment - fewer valves and controls
- Safer operations
- Less manpower

### TULSA Pig Valves

- Provide proven shut-off design to isolate pipeline flow
- Can be used as single or double block and bleed
- Can use most type of pigs
- Have a wide range of fluid compatibility
- Reduce downtime to operate
- Provide one man operation with davit assist — standard for larger valve sizes

### Bidirectional Pig Valve configurations...

1. LAUNCHER  
Launching only.  
No baffle plate.

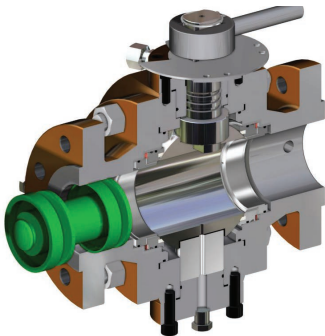

2. RECEIVER  
Receiving only. Baffle  
plate in downstream position.

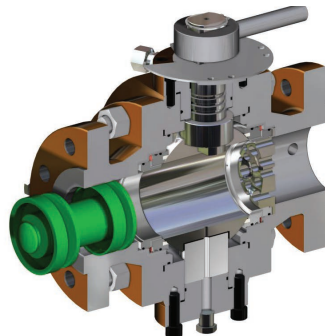

3. LAUNCHER W/ BAFFLE  
Launching & Receiving. Launch  
(as shown) reverse flow to receive.

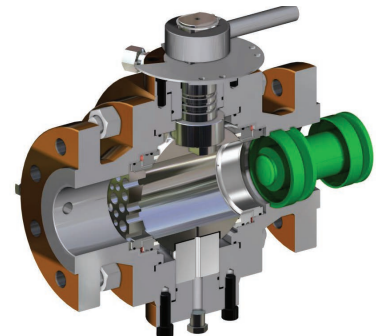

Three pigging operations are possible depending on the position of the catcher plate and the direction of the flow.



# LAUNCHING

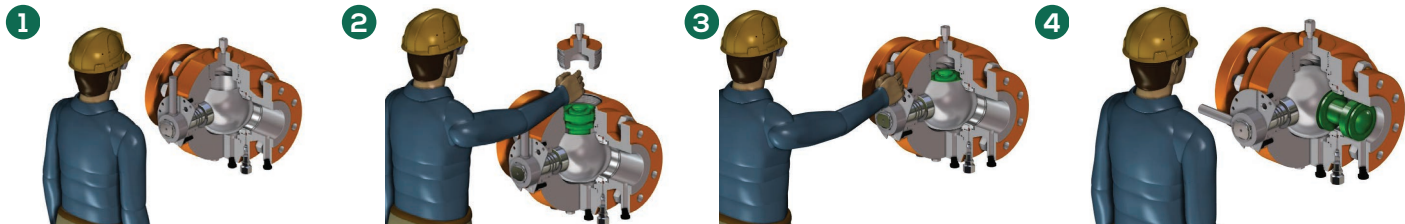

1. Ensure the valve is in the closed position. Vent the body cavity with the bleed fitting on the Entry Cap. After valve is vented, the body fittings may be opened to drain or flush the valve.
2. After venting the body cavity pressure, remove the Entry Cap.  
**CAUTION:** When unscrewing, if gas or liquids start to emerge **STOP!** Screw Entry Cap back on and verify Step 1.
3. Stand facing the valve stem to insert the Pig.  
**NOTE:**
  - Install Pig conical side **DOWN** if flow is from left to right.
  - Install Pig conical side **UP** if flow is from right to left.
4. Before re-installing the Entry Cap on the valve, inspect seal integrity. Then, after ensuring the bleed fitting and all body fittings are closed — open the valve to launch the pig.

# RECEIVING

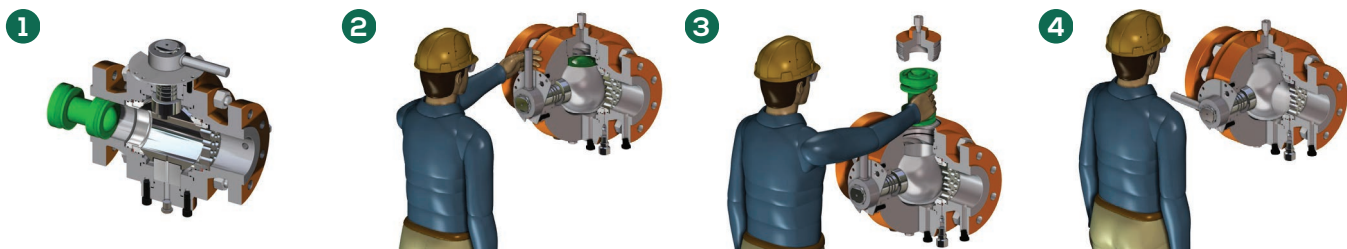

1. Verify valve is installed as a Receiver pig valve with the catcher plate downstream of the flow.
2. When the pig is received, close the valve. Vent the body cavity chamber with the bleed fitting on the Entry Cap. After the valve is vented, the body fittings may be opened to drain or flush the valve, if necessary.
3. Inspect all seals on the Entry Cap to ensure seal integrity. Reinstall the Entry Cap on the valve. Ensure the bleed fitting and all body fittings are closed. Open valve.  
**NOTE:** For easier operation, apply anti-seize to the ACME threads of the Entry Cap.

**CAUTION:** Always dispose of hazardous materials appropriately.

# FEATURES & BENEFITS

TULSA manufactures field proven pig valves

Trunnion Mounted Ball Valve designed in conformance with: API 6D / ASME B16.34 / MSS-SP-61 / NACE

- Fire safe design
- Positive isolation of media flow
- Double Block and Bleed capability

Temperature Range: -50° - 250°F / -45.5° - 121°C (Temperatures up to 400°F / 204°C — available upon request)

## Body (A) & End Connect (B)

- A350-LF2 - Forged material integrity on all pressure containing components
  - Increased confidence in material integrity
  - Reduces NDE requirements
  - Wide temperature range
- Bolted 2 & 3 piece designs
  - Easily field repairable with standard tools
  - Body Studs – A320 L7 / Heavy Hex Nuts – A194 L7
- Body Gasket
  - 304 stainless Spiral Wound Grafoil
- Body drain and vent

## Ball & Seats - 17-4 Stainless Steel

- Wide range of media compatibility, including sweet & sour service
- Seat arrangement with sealing lip provides energized upstream seat for positive shut-off
- Seat arrangement makes body venting downstream automatic
- Primary O-ring seal with secondary seal with SS spiral wound Grafoil gasket
- Metal to metal lip seal provides fire safe design

## Seat Spring - Inconel wave spring

- Longer spring life with superior performance
- Predictable force on ball to seat seal, even at low pressure

## Seat Insert - Devlon V

- Alternate designs available using lip seals instead of O-rings

## Pig Catcher - 17-4 Stainless Steel

- Stainless Steel accommodates a wide range of media compatibility
- Three pigging operations are possible - dependent on pig catcher position and media flow direction.
  1. Launch;
  2. Receive;
  - or 3. Launch & Receive (more details on page 2)

## Stem - Double "D" stem tang design

- Blow-out proof design
  - Flats of the double D allows operation with standard tools
  - Primary O-ring seal is backed with secondary gasket secondary seal
  - Stem upset feature - acts as second trunnion piloting ball on polar ends for stability
  - Piloted on self-lubricating bearing reducing torque
-

### Stem Bonnet

- Primary seal with O-ring backed by stem bonnet gasket for secondary seal - 304 SS spiral wound graphite packing
- Secured with socket head cap screws – A350 L7
- Actuate easily with predrilled ISO 5211 mounting holes standard

### Entry Cap

- Ease of operation — Xylan coated ACME threads provide more lubrication
- Double seal provided with dual O-rings
- Bleed Fitting relieves pressure safely to vent body cavity

### Standard - Ports for equalization or bypass additions

- Predrilled ports are protected with stainless pipe plugs
- Pressure equalization system or bypass adaptation easily added
- Further reduce of torque for easier operation attainable with this addition

### Emergency Injection Port

- Giant stainless button head grease fitting provides easy access
- Internal check valve holds grease in place

### Trunnion

- Longer service life
- More consistent service
- Trunnion Cover with SS Gasket seal protects trunnion
- DU bearings reduce torque to cycle valve

### Lever Handle

- Standard up to 6" (see dimensions on page 8)

### Gear operated and Davit-assist on 6"+

- Standard on larger sizes
- Assist allows one man to operate safely

### Lifting Lugs

- Standard for 6"+

### Lock Plate

- Secures from unwanted tampering
- Prevents use while work is performed downstream

### Stop Plate

- Positive position for Open & Close positions

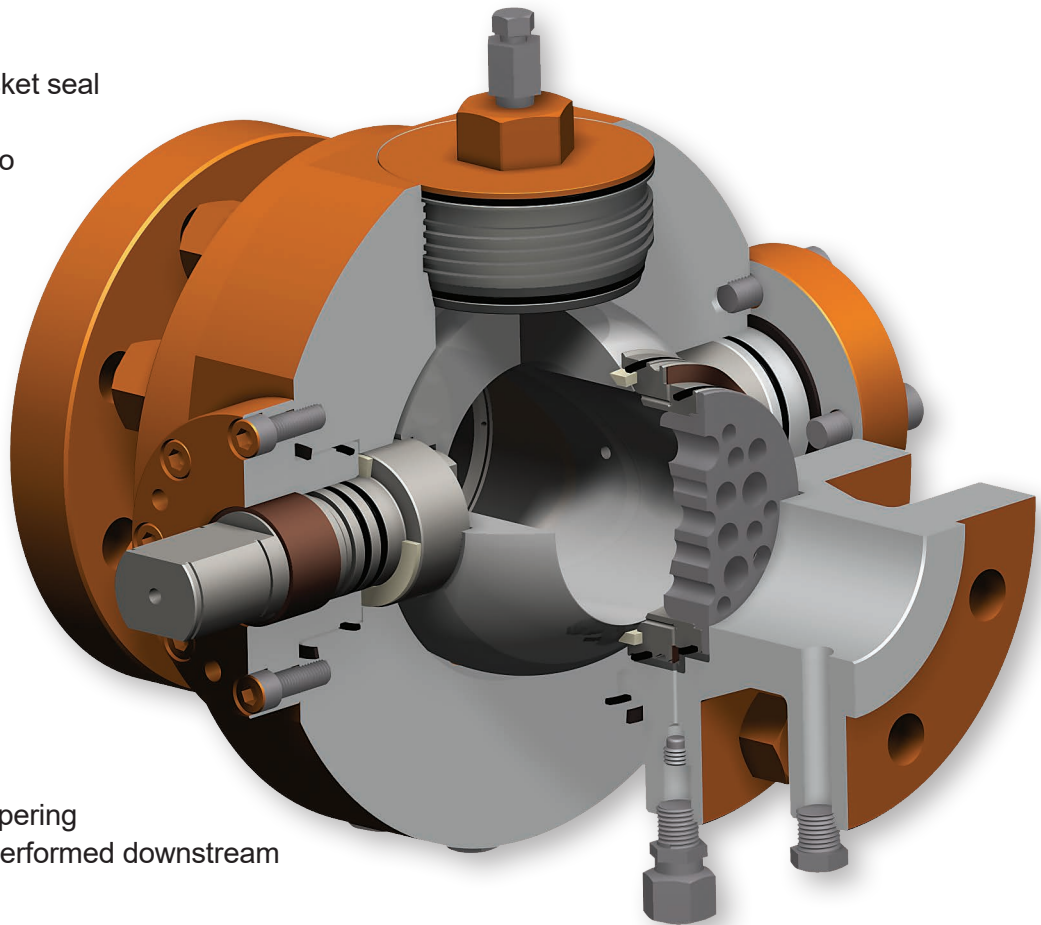

# CONSTRUCTION

- Size: 2" –12", larger upon request
- Pressure: 150-1500 ASME Class
- Body: 3-piece bolted body
- Ball & Seats: Stainless – 17-4PH
- Seat Spring: Inconel wave spring
- Forged Materials: A350 LF2 NACE standard  
Options: Stainless & exotic alloys  
Ends Connections: RF-standard RTJ upon request
- Temperatures: -50° to 400°F / -45° to 204°C  
• Proven shut-off design  
• Bidirectional – use end of line or in closed loop systems
- Alternative: By-pass Pig Valve available for smallest footprint

## Standard Features & Materials

VALVE COMPONENT	MATERIAL
Body & End Connections	A350 LF2
Ball & Seat	17-4 PH H1150+1150
Seat Insert	Devlon V
Seat Spring - wave spring	Inconel X-750
Stem	17-4 PH H1150+1150
Stem Bonnet	A350 LF2
Pig Catcher	17-4 PH H1150+1150
Entry Cap	A350 LF2 w/ Xylan Coated
Trunnion	17-4 PH H1150+1150 stainless
Primary Seals	HNBR-90D
Studs & Nuts (Pressure Containing)	A320 Gr. L7/ A194 Gr. 7
Pipe Plug — protects predrilled port for addition of equalization or bypass system	Stainless Steel
Emergency Injection Grease Fitting with buried check valve	Stainless Steel
Bleed Fitting on Entry Cap (vents body cavity for safe pressure relief)	Stainless Steel
Gasket Seals	304 SS Spiral wound Grafoil

NOTE: Other trim materials available upon request

## Bill of Materials

ITEM	DESCRIPTION	MATERIAL
1	Body	A350 LF2
2	End Connect	A350 LF2
3	Ball	17-4 PH H1150+1150
4	Seat	17-4 PH H1150+1150
5	Seat Insert	Devlon V
6	Wave Spring	Inconel X-750
7	Stem	17-4 PH H1150+1150
8	Stem Bonnet	A350 LF2
9	Catcher	17-4 PH H1150+1150
10	Entry Cap	A350 LF2 w/ Xylan Coated
11	Trunnion	17-4 PH H1150+1150
12	Trunnion Cover	A350 LF2
13	Stem Thrust Bearing (not shown)	15% Glass reinforced Teflon
14	Ball Thrust Bearing (not shown)	15% Glass reinforced Teflon
15	Lock Plate (not shown)	A36
16	Stop Plate (not shown)	A36
17	Lever / Handle (not shown)	A572
18	Gear Plate (6"+) (not shown)	A36
19	Gear (6"+) (not shown)	
20	O-ring (Stem Bonnet)	HNBR-90D
21	O-ring (End Connect)	HNBR-90D
22	O-ring (Seat Primary)	HNBR-90D
23	O-ring (Seat Secondary)	HNBR-90D
24	O-ring (Cap Primary)	HNBR-90D
25	O-ring (Trunnion Cover)	HNBR-90D
26	O-ring (Stem)	HNBR-90D
27	O-ring (Cap Secondary)	HNBR-90D
28	DU Bearing	DU
29	DU Bearing (not shown)	DU
30	Body Studs	A320 Gr. L7
31	Heavy Hex Nuts	A194 Gr. 7
32	Socket Head Cap Screw (Stem Bonnet)	A320 Gr. L7
33	Socket Head Cap Screw (Trunnion)	A320 Gr. L7
34	Pipe Plug	Stainless Steel
35	Buried Check	Stainless Steel
36	Grease Fitting	Stainless Steel
37	Entry Cap Bleed Fitting	Stainless Steel
38	Body Gasket	304 SS Spiral wound Grafoil
39	Stem Bonnet Gasket	304 SS Spiral wound Grafoil
40	Trunnion Cover Gasket	304 SS Spiral wound Grafoil



### Service Applications

- Sweet or Sour petroleum
- Chemical & Processing plants
- Food processing
- Salt water

TULSA Pig Valves are suitable for many applications. The 17-4 stainless steel NACE Ball, Seat and Pig Catcher is a high-strength material that is chemical, abrasion and corrosion resistant.

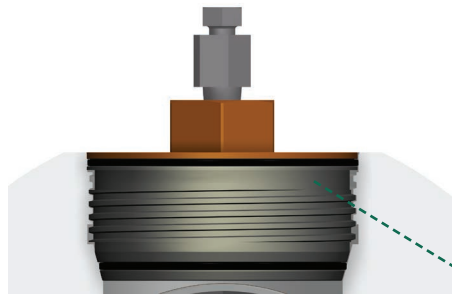

### CAP

- One man operation
- Davit assist standard for larger sizes

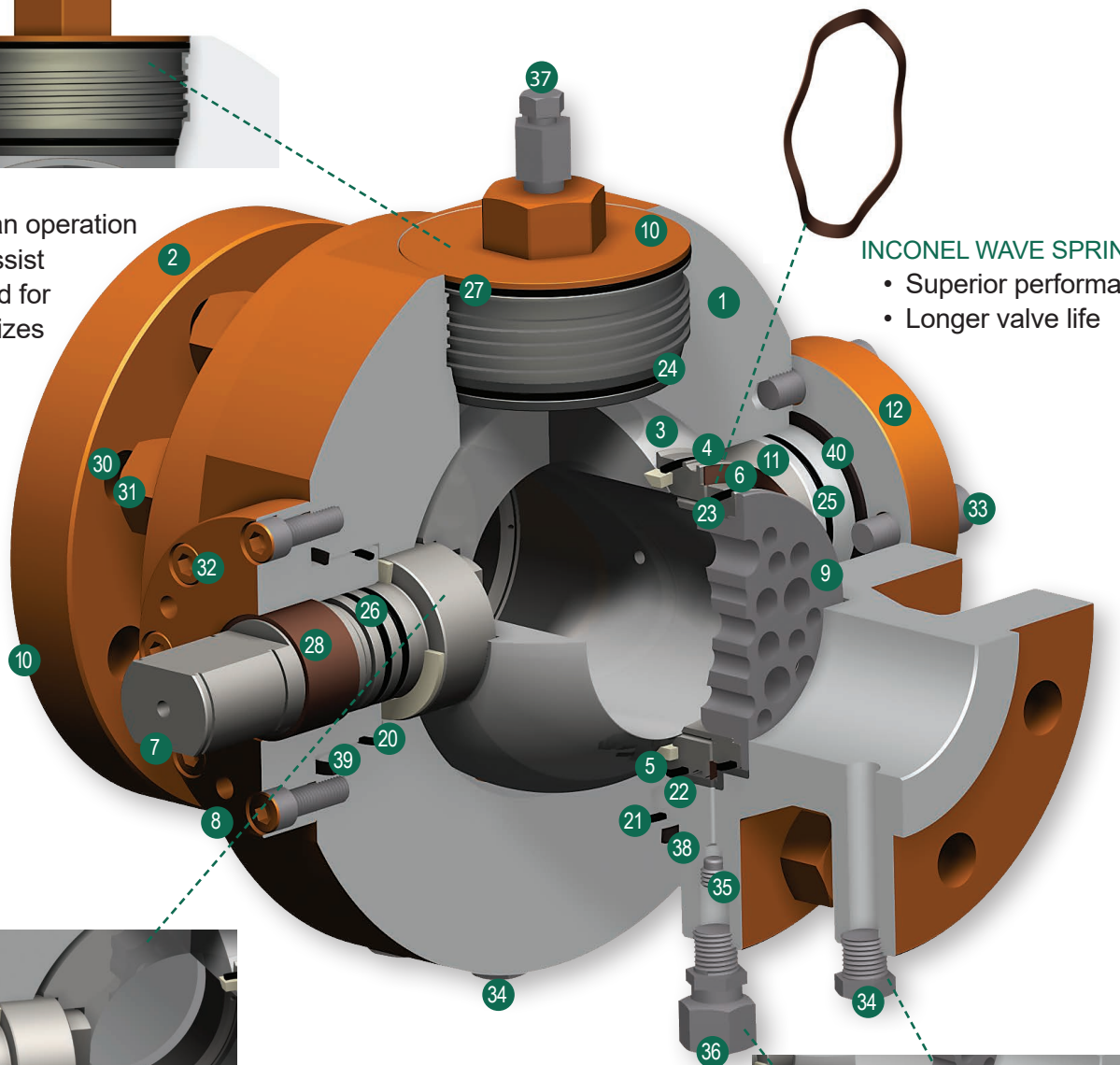

### INCONEL WAVE SPRING

- Superior performance
- Longer valve life

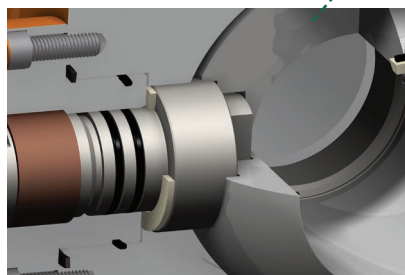

### STEM

- Blow-out proof/double D design

### EQUALIZATION OR BYPASS PIPING

- Easy Assembly

### EMERGENCY SEALANT INJECTION

# SHUT-OFF PIG VALVES

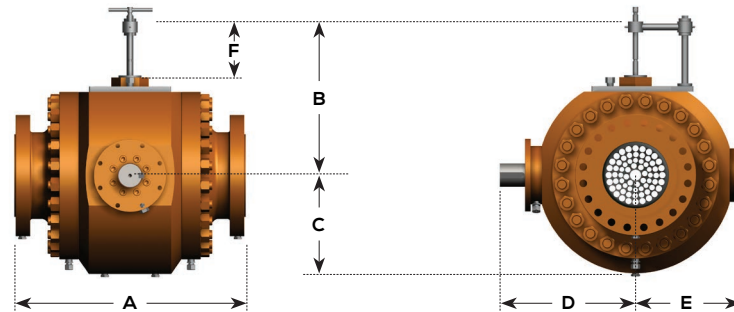

### Dimensions & Weights

Size	A		B		C		D		E		F		Ball ID		Pig Entry		Valve Bore		Approx. Wt.	
	in	mm	in	mm	in	mm	in	mm	in	mm	in	mm	in	mm	in	mm	in	mm	lbs	kg
<b>2 inch</b>																				
150 RF	11.50	292.10	6.01	152.65	5.40	137.16	7.69	195.33	5.87	149.10	N/A	N/A	2.50	63.50	2.90	73.66	2.01	51.05	204	92.41
150 RTJ	11.88	301.75	6.01	152.65	5.40	137.16	7.69	195.33	5.87	149.10	N/A	N/A	2.50	63.50	2.90	73.66	2.01	51.05	204	92.41
300 RF	14.25	361.95	6.01	152.65	5.40	137.16	7.69	195.33	5.87	149.10	N/A	N/A	2.50	63.50	2.90	73.66	2.01	51.05	204	92.41
300 RTJ	14.62	371.35	6.01	152.65	5.40	137.16	7.69	195.33	5.87	149.10	N/A	N/A	2.50	63.50	2.90	73.66	2.01	51.05	204	92.41
600 RF	14.25	361.95	6.01	152.65	5.40	137.16	7.69	195.33	5.87	149.10	N/A	N/A	2.50	63.50	2.90	73.66	2.01	51.05	216	97.85
600 RTJ	14.62	371.35	6.01	152.65	5.40	137.16	7.69	195.33	5.87	149.10	N/A	N/A	2.50	63.50	2.90	73.66	2.01	51.05	216	97.85
900 RF	14.50	368.30	6.30	160.02	6.30	160.02	8.97	227.84	6.74	171.20	N/A	N/A	2.50	63.50	2.90	73.66	2.01	51.05	300	136.08
900 RTJ	14.62	371.35	6.30	160.02	6.30	160.02	8.97	227.84	6.74	171.20	N/A	N/A	2.50	63.50	2.90	73.66	2.01	51.05	300	136.08
1500 RF	15.13	384.18	6.30	160.02	6.30	160.02	8.97	227.84	6.74	171.20	N/A	N/A	2.50	63.50	2.90	73.66	2.01	51.05	318	144.24
1500 RTJ	15.25	387.35	6.30	160.02	6.30	160.02	8.97	227.84	6.74	171.20	N/A	N/A	2.50	63.50	2.90	73.66	2.01	51.05	318	144.24
<b>3 inch</b>																				
150 RF	12.75	323.85	6.75	171.45	6.25	158.75	9.25	234.95	6.63	168.40	N/A	N/A	3.50	88.90	3.60	91.44	3.13	79.38	247	111.89
150 RTJ	13.13	333.50	6.75	171.45	6.25	158.75	9.25	234.95	6.63	168.40	N/A	N/A	3.50	88.90	3.60	91.44	3.13	79.38	247	111.89
300 RF	14.00	355.60	6.75	171.45	6.25	158.75	9.25	234.95	6.63	168.40	N/A	N/A	3.50	88.90	3.60	91.44	3.13	79.38	258	116.87
300 RTJ	14.12	358.65	6.75	171.45	6.25	158.75	9.25	234.95	6.63	168.40	N/A	N/A	3.50	88.90	3.60	91.44	3.13	79.38	258	116.87
600 RF	14.00	355.60	6.75	171.45	6.25	158.75	9.25	234.95	6.63	168.40	N/A	N/A	3.50	88.90	3.60	91.44	3.13	79.38	267	120.95
600 RTJ	14.13	358.90	6.75	171.45	6.25	158.75	9.25	234.95	6.63	168.40	N/A	N/A	3.50	88.90	3.60	91.44	3.13	79.38	267	120.95
900 RF*	15.00	381.00	6.97	177.04	6.80	172.72	10.24	260.10	7.35	186.69	N/A	N/A	3.50	88.90	3.60	91.44	3.13	79.38	395	179.17
900 RTJ*	15.12	384.05	6.97	177.04	6.80	172.72	10.24	260.10	7.35	186.69	N/A	N/A	3.50	88.90	3.60	91.44	3.13	79.38	395	179.17
1500 RF*	18.90	480.06	6.97	177.04	6.80	172.72	10.24	260.10	7.35	186.69	N/A	N/A	3.50	88.90	3.60	91.44	3.13	79.38	476	215.91
1500 RTJ*	19.02	483.11	6.97	177.04	6.80	172.72	10.24	260.10	7.35	186.69	N/A	N/A	3.50	88.90	3.60	91.44	3.13	79.38	476	215.91
<b>4 inch</b>																				
150 RF	15.50	393.70	7.35	186.69	7.05	179.07	10.10	256.54	7.55	191.77	N/A	N/A	4.50	114.30	4.60	116.84	4.00	101.60	371	168.28
150 RTJ	16.00	406.40	7.35	186.69	7.05	179.07	10.10	256.54	7.55	191.77	N/A	N/A	4.50	114.30	4.60	116.84	4.00	101.60	371	168.28
300 RF	16.00	406.40	7.35	186.69	7.05	179.07	10.10	256.54	7.55	191.77	N/A	N/A	4.50	114.30	4.60	116.84	4.00	101.60	392	177.81
300 RTJ	16.62	422.15	7.35	186.69	7.05	179.07	10.10	256.54	7.55	191.77	N/A	N/A	4.50	114.30	4.60	116.84	4.00	101.60	392	177.81
600 RF	17.00	431.80	7.35	186.69	7.05	179.07	10.10	256.54	7.55	191.77	N/A	N/A	4.50	114.30	4.60	116.84	4.00	101.60	410	185.73
600 RTJ	17.12	434.85	7.35	186.69	7.05	179.07	10.10	256.54	7.55	191.77	N/A	N/A	4.50	114.30	4.60	116.84	4.00	101.60	410	185.73
900 RF*	18.00	457.20	8.38	212.85	8.45	214.63	13.55	344.17	9.10	231.14	N/A	N/A	4.50	114.30	4.60	116.84	4.00	101.60	710	322.05
900 RTJ*	18.12	460.25	8.38	212.85	8.45	214.63	13.55	344.17	9.10	231.14	N/A	N/A	4.50	114.30	4.60	116.84	4.00	101.60	710	322.05
1500 RF*	21.50	546.10	8.38	212.85	8.45	214.63	13.55	344.17	9.10	231.14	N/A	N/A	4.50	114.30	4.60	116.84	4.00	101.60	820	371.95
1500 RTJ*	21.62	549.15	8.38	212.85	8.45	214.63	13.55	344.17	9.10	231.14	N/A	N/A	4.50	114.30	4.60	116.84	4.00	101.60	820	371.95

\*Valves standard with gear and davit. Request general assembly drawings for gear and davit dimensions.

Other sizes available upon request.

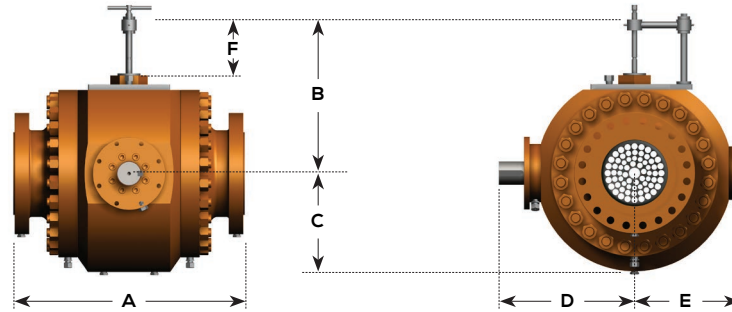

Dimensions & Weights

Size	A		B		C		D		E		F		Ball ID		Pig Entry		Valve Bore		Approx. Wt.	
	in	mm	in	mm	in	mm	in	mm	in	mm	in	mm	in	mm	in	mm	in	mm	lbs	kg
<b>6 inch</b>																				
150 RF*	18.00	457.20	9.86	250.49	9.40	238.76	13.49	342.65	10.18	258.57	N/A	N/A	6.75	171.45	6.50	165.10	6.00	152.40	799	362.42
150 RTJ*	18.38	466.85	9.86	250.49	9.40	238.76	13.49	342.65	10.18	258.57	N/A	N/A	6.75	171.45	6.50	165.10	6.00	152.40	799	362.42
300 RF*	18.88	479.55	9.86	250.49	9.40	238.76	13.49	342.65	10.18	258.57	N/A	N/A	6.75	171.45	6.50	165.10	6.00	152.40	848	384.65
300 RTJ*	19.38	492.25	9.86	250.49	9.40	238.76	13.49	342.65	10.18	258.57	N/A	N/A	6.75	171.45	6.50	165.10	6.00	152.40	848	384.65
600 RF*	22.00	558.80	9.86	250.49	9.40	238.76	13.49	342.65	10.18	258.57	N/A	N/A	6.75	171.45	6.50	165.10	6.00	152.40	990	449.06
600 RTJ*	22.12	561.85	9.86	250.49	9.40	238.76	13.49	342.65	10.18	258.57	N/A	N/A	6.75	171.45	6.50	165.10	6.00	152.40	990	449.06
900 RF*	24.00	609.60	12.00	304.80	11.40	289.56	18.05	458.47	11.78	299.21	N/A	N/A	6.75	171.45	6.50	165.10	6.00	152.40	1600	724.80
900 RTJ*	24.12	612.65	12.00	304.80	11.40	289.56	18.05	458.47	11.78	299.21	N/A	N/A	6.75	171.45	6.50	165.10	6.00	152.40	1600	724.80
1500 RF*	27.75	704.85	12.00	304.80	11.40	289.56	18.05	458.47	11.78	299.21	N/A	N/A	6.75	171.45	6.50	165.10	6.00	152.40	1615	731.60
1500 RTJ*	28.00	711.20	12.00	304.80	11.40	289.56	18.05	458.47	11.78	299.21	N/A	N/A	6.75	171.45	6.50	165.10	6.00	152.40	1615	731.60
<b>8 inch</b>																				
150 RF*	25.12	638.05	23.71	602.23	13.50	342.90	19.50	495.30	14.47	367.54	9.74	247.40	9.38	238.25	9.25	234.95	8.01	203.45	2288	1036.46
150 RTJ*	25.50	647.70	23.71	602.23	13.50	342.90	19.50	495.30	14.47	367.54	9.74	247.40	9.38	238.25	9.25	234.95	8.01	203.45	2288	1036.46
300 RF*	28.50	723.90	23.71	602.23	13.50	342.90	19.50	495.30	14.47	367.54	9.74	247.40	9.38	238.25	9.25	234.95	8.01	203.45	2440	1105.32
300 RTJ*	29.00	736.60	23.71	602.23	13.50	342.90	19.50	495.30	14.47	367.54	9.74	247.40	9.38	238.25	9.25	234.95	8.01	203.45	2440	1105.32
600 RF*	31.20	792.48	23.71	602.23	13.50	342.90	19.50	495.30	14.47	367.54	9.74	247.40	9.38	238.25	9.25	234.95	8.01	203.45	2750	1245.75
600 RTJ*	31.32	795.53	23.71	602.23	13.50	342.90	19.50	495.30	14.47	367.54	9.74	247.40	9.38	238.25	9.25	234.95	8.01	203.45	2750	1245.75
900 RF*	35.00	889.00	25.97	659.64	16.45	417.83	23.12	587.25	17.52	445.01	9.74	247.40	9.38	238.25	9.25	234.95	8.01	203.45	4984	2260.70
900 RTJ*	35.12	892.05	25.97	659.64	16.45	417.83	23.12	587.25	17.52	445.01	9.74	247.40	9.38	238.25	9.25	234.95	8.01	203.45	4984	2260.70
1500 RF*	39.12	993.65	25.97	659.64	16.45	417.83	23.12	587.25	17.52	445.01	9.74	247.40	9.38	238.25	9.25	234.95	8.01	203.45	5226	2370.47
1500 RTJ*	39.50	1003.30	25.97	659.64	16.45	417.83	23.12	587.25	17.52	445.01	9.74	247.40	9.38	238.25	9.25	234.95	8.01	203.45	5226	2370.47
<b>10 inch</b>																				
150 RF*	30.80	782.32	25.17	639.32	14.00	355.60	20.06	509.52	15.07	382.78	9.77	248.16	10.50	266.70	10.60	269.24	10.00	254.00	3164	1433.29
150 RTJ*	31.18	791.97	25.17	639.32	14.00	355.60	20.06	509.52	15.07	382.78	9.77	248.16	10.50	266.70	10.60	269.24	10.00	254.00	3164	1433.29
300 RF*	35.36	898.14	25.17	639.32	14.00	355.60	20.06	509.52	15.07	382.78	9.77	248.16	10.50	266.70	10.60	269.24	10.00	254.00	3350	1517.55
300 RTJ*	35.86	910.84	25.17	639.32	14.00	355.60	20.06	509.52	15.07	382.78	9.77	248.16	10.50	266.70	10.60	269.24	10.00	254.00	3350	1517.55
600 RF*	37.12	942.85	25.17	639.32	14.00	355.60	20.06	509.52	15.07	382.78	9.77	248.16	10.50	266.70	10.60	269.24	10.00	254.00	3526	1597.28
600 RTJ*	37.25	946.15	25.17	639.32	14.00	355.60	20.06	509.52	15.07	382.78	9.77	248.16	10.50	266.70	10.60	269.24	10.00	254.00	3526	1597.28
<b>12 inch</b>																				
150 RF*	35.00	889.00	27.96	710.18	17.85	453.39	24.67	626.62	19.25	488.95	9.77	248.16	13.00	330.20	12.60	320.04	12.06	306.40	5655	2561.72
150 RTJ*	35.38	898.65	27.96	710.18	17.85	453.39	24.67	626.62	19.25	488.95	9.77	248.16	13.00	330.20	12.60	320.04	12.06	306.40	5655	2561.72
300 RF*	40.75	1035.05	27.96	710.18	17.85	453.39	24.67	626.62	19.25	488.95	9.77	248.16	13.00	330.20	12.60	320.04	12.06	306.40	6000	2718.00
300 RTJ*	41.25	1047.75	27.96	710.18	17.85	453.39	24.67	626.62	19.25	488.95	9.77	248.16	13.00	330.20	12.60	320.04	12.06	306.40	6000	2718.00
600 RF*	42.06	1068.32	27.96	710.18	17.85	453.39	24.67	626.62	19.25	488.95	9.77	248.16	13.00	330.20	12.60	320.04	12.06	306.40	6150	2785.95
600 RTJ*	42.19	1071.63	27.96	710.18	17.85	453.39	24.67	626.62	19.25	488.95	9.77	248.16	13.00	330.20	12.60	320.04	12.06	306.40	6150	2785.95

\*Valves standard with gear and davit. Request general assembly drawings for gear and davit dimensions.

Other sizes available upon request.

# PRESSURE-TEMPERATURE

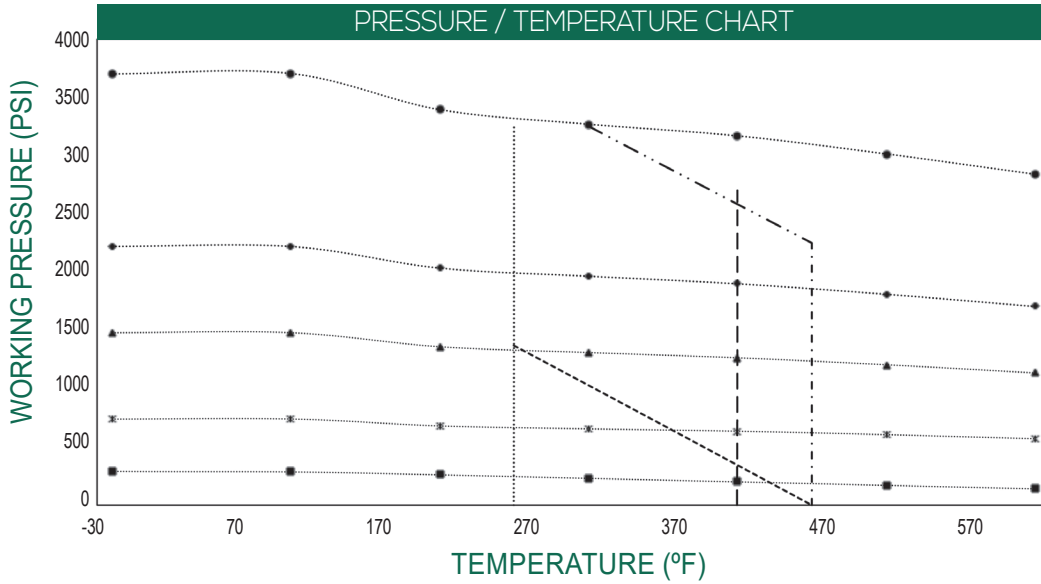

.....■.....	150 CLASS: MATERIAL GROUP 1.1
.....*.....	300 CLASS: MATERIAL GROUP 1.1
.....▲.....	600 CLASS: MATERIAL GROUP 1.1
.....◆.....	900 CLASS: MATERIAL GROUP 1.1
.....●.....	1500 CLASS: MATERIAL GROUP 1.1
.....	NYLON, BUNA-N, & LT BUNA-N
-----	TEFLON
- . - . -	AFLAS OR EPDM
————	VITON
— · — · —	PEEK

MATERIAL GROUP 1.1 (A350 LF2, A216 WCB)  
PER ASME 16.34

Recommended Pig Sizes			
Valve size	A	B	Durometer
2	2.25	4.05	70, 80, 90
3	3.38	5.63	70, 80, 90
4	4.25	6.75	70, 80, 90
6	6.38	10.75	70, 80, 90
8	8.38	14.00	70, 80, 90
10	10.38	17.25	70, 80, 90
12	12.38	19.00	70, 80, 90

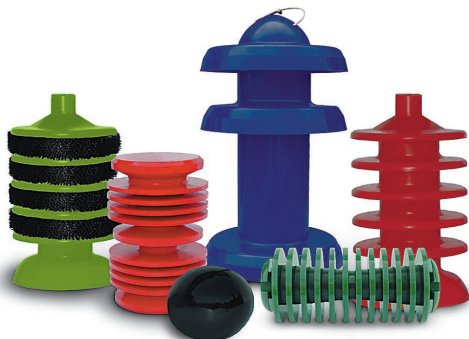
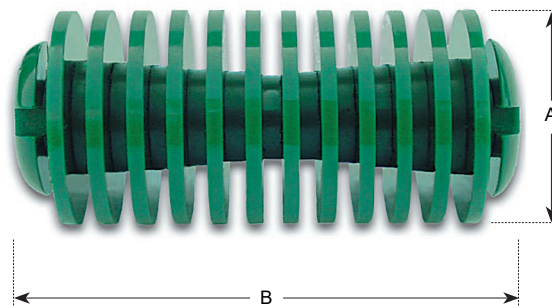

A variety of Pig styles can be used.

(Pig photos courtesy of Pigs Unlimited)

Temp (°F)	Working Pressure (psi)
<b>150 CLASS: MATERIAL GROUP 1.1</b>	
-20°	285
100°	285
200°	260
300°	230
400°	200
500°	170
600°	140
<b>300 CLASS: MATERIAL GROUP 1.1</b>	
-20°	740
100°	740
200°	680
300°	655
400°	635
500°	605
600°	570
<b>600 CLASS: MATERIAL GROUP 1.1</b>	
-20°	1480
100°	1480
200°	1360
300°	1310
400°	1265
500°	1205
600°	1135
<b>900 CLASS: MATERIAL GROUP 1.1</b>	
-20°	2220
100°	2220
200°	2035
300°	1965
400°	1900
500°	1810
600°	1705
<b>1500 CLASS: MATERIAL GROUP 1.1</b>	
-20°	3705
100°	3705
200°	3395
300°	3270
400°	3170
500°	3015
600°	2840
<b>NYLON, BUNA-N, &amp; LT BUNA-N</b>	
250°	0
250°	3250
<b>TEFLON</b>	
250°	1375
450°	0
<b>AFLAS OR EPDM</b>	
450°	0
450°	2250
<b>VITON</b>	
400°	0
400°	2700
<b>PEEK</b>	
300°	3250
450°	2250



# TULSA PIG VALVE

- Is a USA based OEM with a range economical, reliable valves used in oil and gas applications

## VALUE ADDED SERVICE

- Site Evaluation
- Pig Valve Training – on site or at our factory
- Field Commissioning
- Maintenance Services
- Repair Programs



Training on site and Field Commissioning

## MORE FROM TULSA PIG VALVE

- By-pass Pigging Valves



# PRODUCTS

## Wellhead - Midstream

Tulsa Pig Valves, LLC is a leading manufacturer and distributor of pressure, flow control, and automation equipment for oil and gas exploration, production, gathering and distribution systems. Products in partnership with Cactus Flow Products include chokes, other flow control products, shut-off pig valves, and bypass pig valves.

# SERVICES

## Design - Aftermarket

As Original Equipment Manufacturers (OEM), Tulsa Pig Valves has the background, technical expertise and resources to provide the support your team needs so you can stay focused on your objectives. Services provided are:

- Engineering support, custom design, and forensic analysis
- Repairs from frac valves to BOPs, troubleshooting, and maintenance



## PRODUCTS



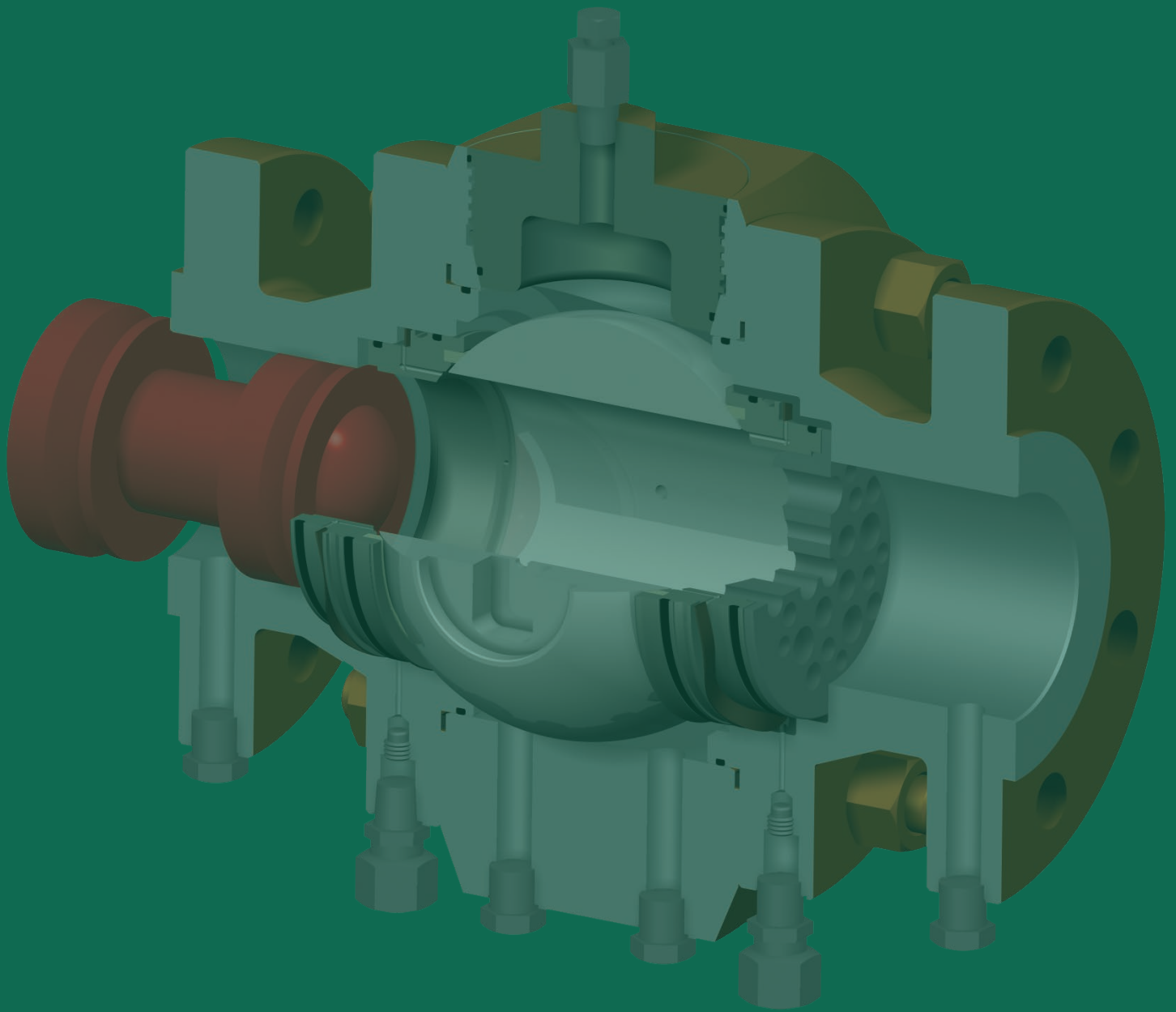

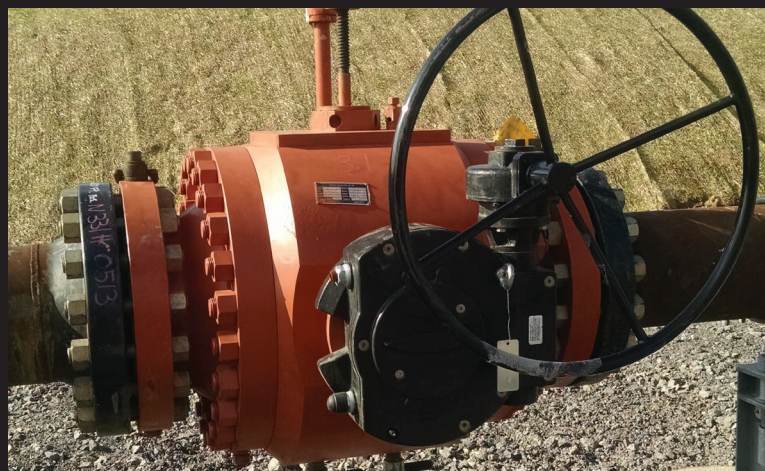
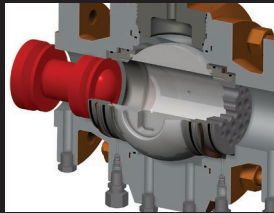
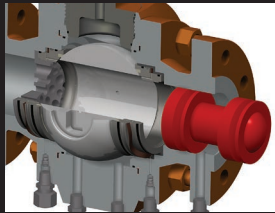
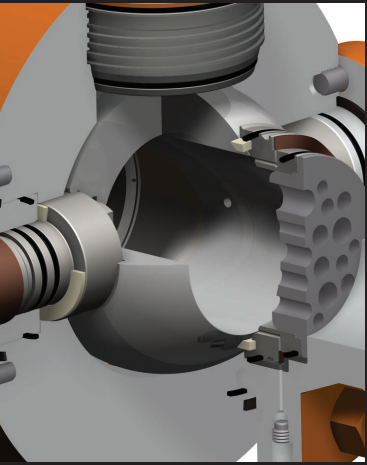

TULSA PIG VALVES  
A CACTUS FLOW PRODUCTS COMPANY

CORPORATE OFFICE  
15900 Morales Road  
Houston, TX 77032  
Toll Free: 844.332.5155  
Phone: 281.909.3680  
Fax: 281.260.8376